

Knocker Fitting Detail

- 1** The Fab & Fix knocker fits to the door profile using a discrete bracket that is unseen when the knocker is fitted. Ensure that the bracket has retained the two washers and place the bracket, correct side up and with the attached washers facing the door.

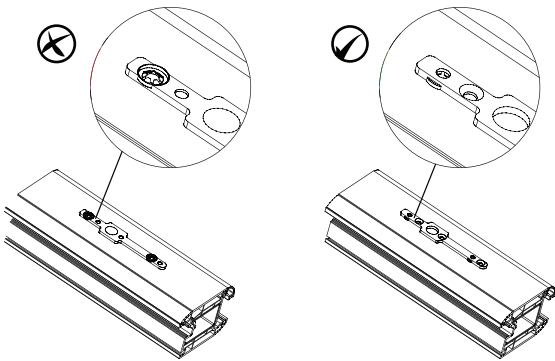

- 2** With the knocker bracket correctly located mark the fixing holes with a pen or pencil. 5 holes in total unless fitting a spyhole viewer.

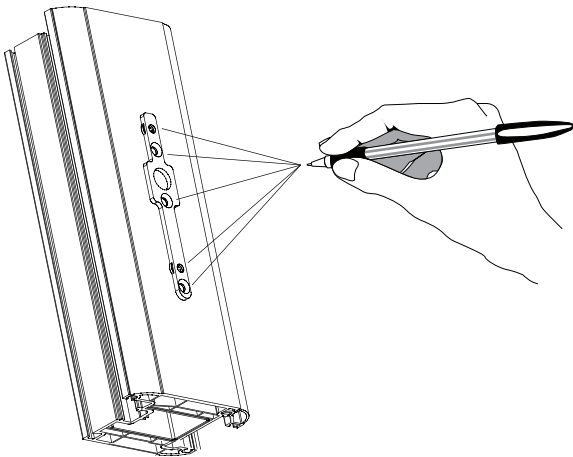

- 3** If available always use a drill punch to mark drilling positions using the pencil marks as a guide. The indent made by the point will ensure the drill does not slip.

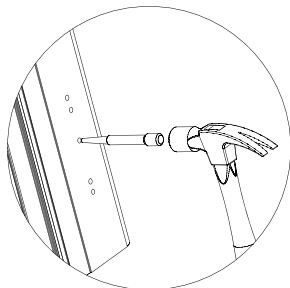

- 4** If fitting to PVCu profile pre-drill the fixing holes ensuring the drill bit pierces the steel re-inforcement. If fitting to timber drill to a maximum depth of 15mm. You will require both a 2mm drill bit and a 5mm drill bit.

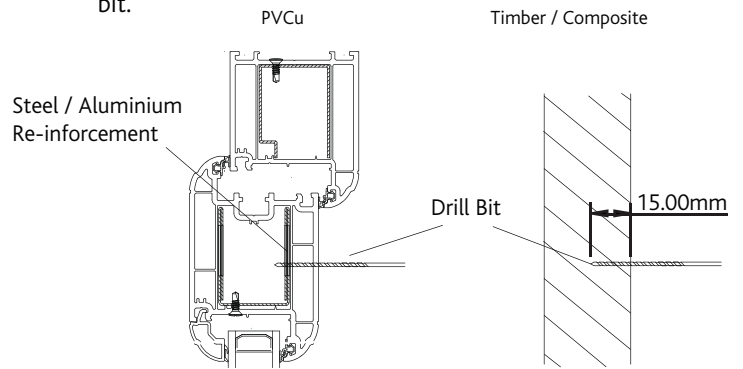

- The two holes with washers underneath will require a 5mm drill bit. The three counter-sunk holes will require a 2mm drill bit.

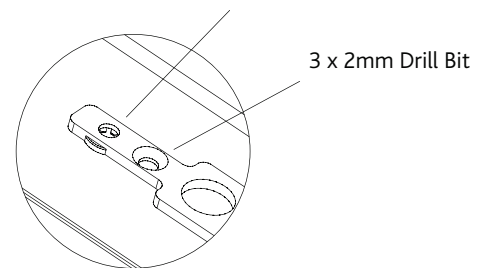

- 5** Place the bracket in the correct place with the two washers sitting over the 5mm drilled holes. Screw into place using 3.5mm PVCu screws into the three counter-sunk holes on the bracket. Once screwed into place the knocker can be pushed onto the bracket ensuring the fixing lugs enter the washers. The knocker may require a gentle tapping to ensure good fit and alignment.

